

Montage / Installation / Einbau / Montage

**Samenstelling / Assembling /
Zusammenstellung / Composition**

Bedieningsas / Operating shaft /
Betätigungsachse / Arbre de commande

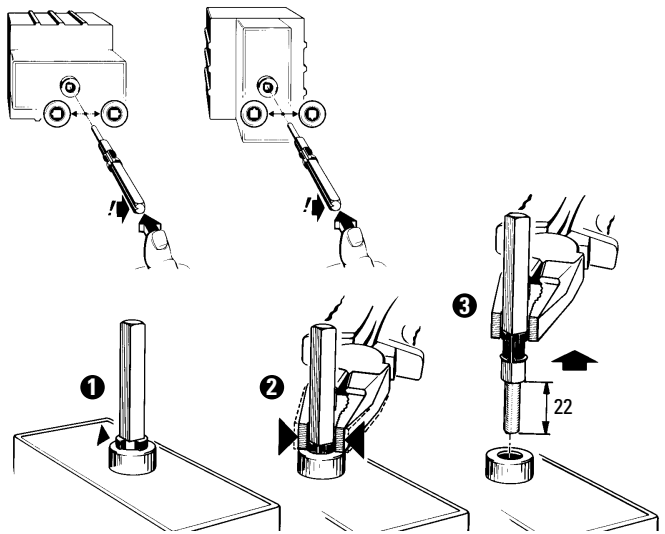

**Bevestigingsmogelijkheden / mounting options /
Befestigungsmöglichkeiten / possibilités de fixation**

Hoedprofiel / Top hat rail /
Hutschiene / Profilé chapeau

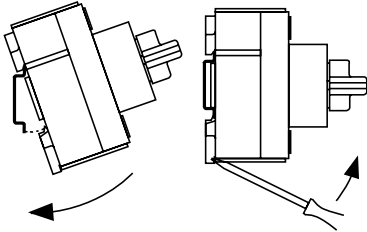

Voorzijde / Front /
Vorderseite / Face avant

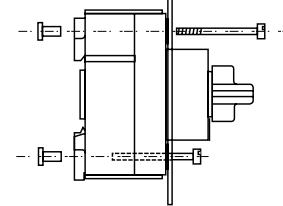

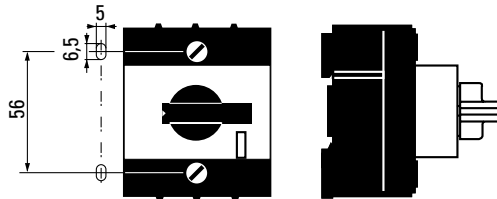

Bodem / Bottom / Boden / Plaque de fond

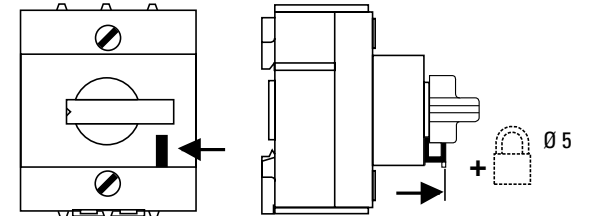
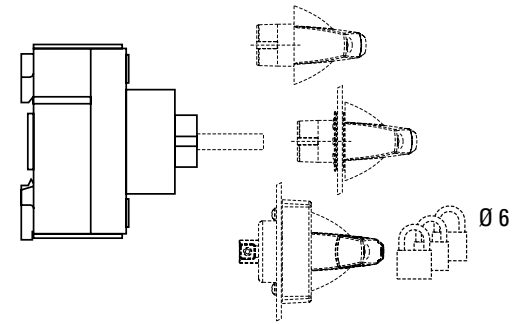

Uitvoeringsvorm / Version / Ausführungsform



Aansluiting / Connection / Verbindungen / Raccordement**Aansluitbereik / Connection capacity /
Anschlußräume / Capacité de raccordement**

Geleider / Conductor / Leiter / Conducteur mm ²	DCM 40 - 63
	2,5÷16
	1,5÷25
	1,5÷25
Aanhaalmoment / Tightening torque Anzugsdrehmoment / Couple de serrage	3 Nm

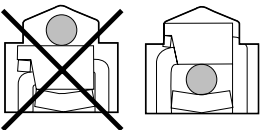
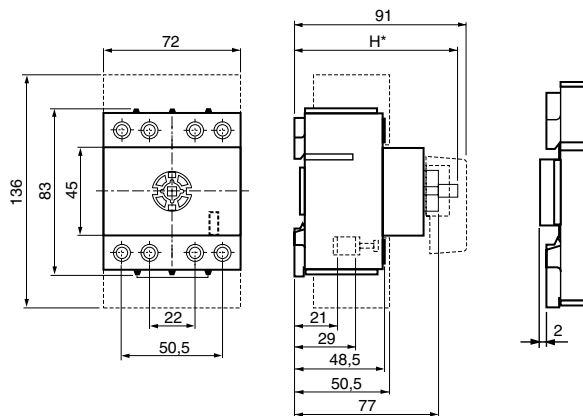
**Inklemming / Clamping /
Einklemmung / Connexion à pince****Afmetingen / Dimensions / Abmessungen**

* Afhankelijk van de toegepaste bedieningsas / Depending on length of operating shaft /
Abhängig von der verwendeten Betätigungsachse / En fonction de l'arbre de commande utilisé

Accessoires / Accessories/ Zubehör/ Accessoires

- Asondersteuningsset / Shaft supporting set / Achsunterstützungssatz / Ensemble de support pour l'arbre
- Doorvoering met standengrendeling / Escutcheon with position locking / Durchführung mit Stellungsverriegelung / Traversée avec verrouillage de position
- Afschermkap / Protective cover / Abschirmhaube / Capot de protection
- Hulpschakelaarset / Auxiliary switch set / Hilfsschalersatz / Ensemble d'interrupteur auxiliaire
- Aansluitset / Connection set / Anschlußsatz / Ensemble de raccordement

Eaton Electric B.V.

Postbus 23

7550 AA Hengelo

Tel.: 074 246 32 22

Fax: 074 246 33 02

steunpunt@eaton.com

www.et-installateur.nl

© 2009 Eaton Electric N.V. Gedetailleerde of gehele overname van de inhoud is mogelijk na schriftelijke toestemming van Eaton Electric N.V. MBO 1991044G01 001/SWB/SGS/Januari 2009

EATON**LS-lastscheiders / LV-switch-disconnectors /
NS-Lasttrennschalter / Interrupteurs-sectionneurs BT**

MBO 1991044G01 001

Duco types DCM 40, DCM 63**CE**