

## MFD-Titan

MFD-...-CP8...  
MFD-...-CP10...  
MFD-80-...  
MFD-T...  
MFD-R...  
EASY618-...-RE  
EASY620-DC-TE  
EASY200-EASY  
EASY202-RE  
EASY410-DC-...

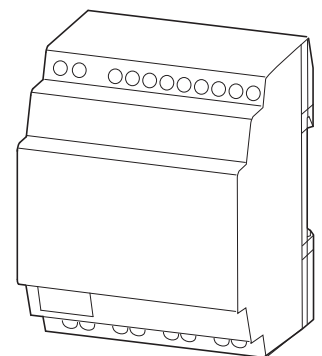
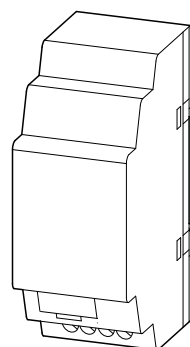
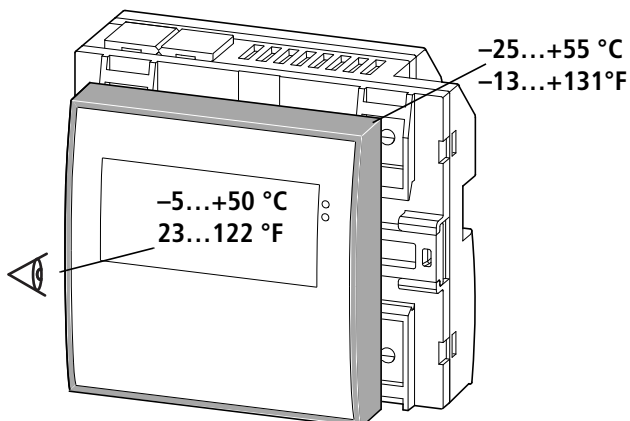
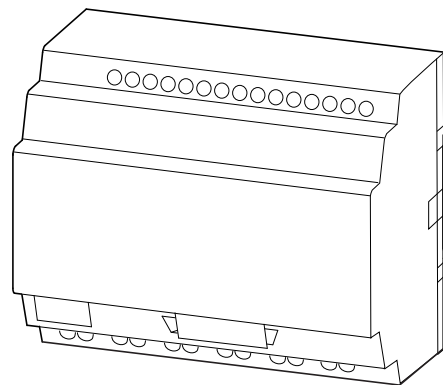
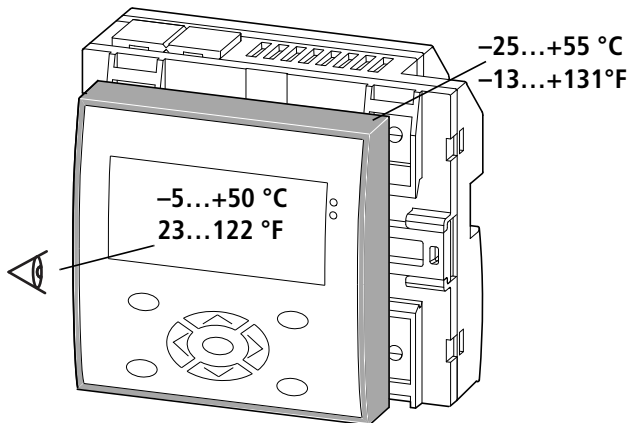
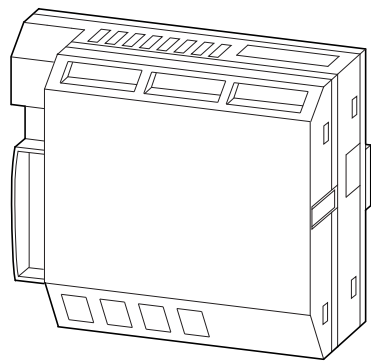
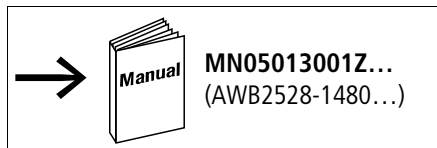

**(en) Electric current! Danger to life!**

Only skilled or instructed persons may carry out the following operations. The national regulations/specifications must be observed for the installation of the devices.

**(de) Lebensgefahr durch elektrischen Strom!**

Nur Elektrofachkräfte und elektrotechnisch unterwiesene Personen dürfen die im Folgenden beschriebenen Arbeiten ausführen. Die Stromversorgungsgeräte sind Einbaugeräte. Beachten Sie für die Installation der Geräte die länderspezifischen Vorschriften.

**(fr) Tension électrique dangereuse !**

Seules les personnes qualifiées et averties doivent exécuter les travaux ci-après. Les blocs d'alimentation sont des appareils faisant partie intégrante d'une installation. Veuillez respecter les normes de mise en œuvre spécifiques aux différents pays.

**(es) ¡Corriente eléctrica! ¡Peligro de muerte!**

El trabajo a continuación descrito debe ser realizado por personas cualificadas y advertidas. Las fuentes de alimentación son aparatos de montaje. Para la instalación de los aparatos han de tenerse en cuenta las normativas/especificaciones a nivel local.

**(it) Tensione elettrica: Pericolo di morte!**

Solo persone abilitate e qualificate possono eseguire le operazioni di seguito riportate. Gli alimentatori sono unità per montaggio interno. Per l'installazione degli apparecchi è necessario rispettare le normative specifiche di ciascun paese.

**Standard connection – Standardanschluss – Raccordement standard – Conexión estándar – Collegamento standard**  
**Power supply – Spannungsversorgung – Tension d'alimentation – Tensión de alimentación – Tensione di alimentazione**

**MFD-CP8.../MFD-CP10...**

**MFD-AC-CP8...**

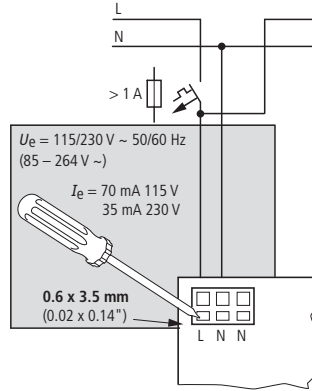
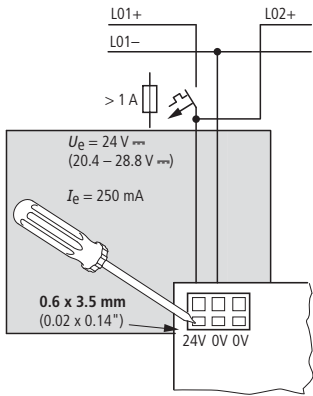

Digital inputs, analog inputs, analog output – Digital-Eingänge, Analog-Eingänge, Analog-Ausgang – Entrées TOR, entrées analogiques, sortie analogique – Entradas digitales, entradas analógicas, salida analógica – Ingressi digitali, ingressi analogici, uscita analogica

**MFD-CP8.../MFD-CP10... + MFD-R..., MFD-CP8.../MFD-CP10... + MFD-T...**

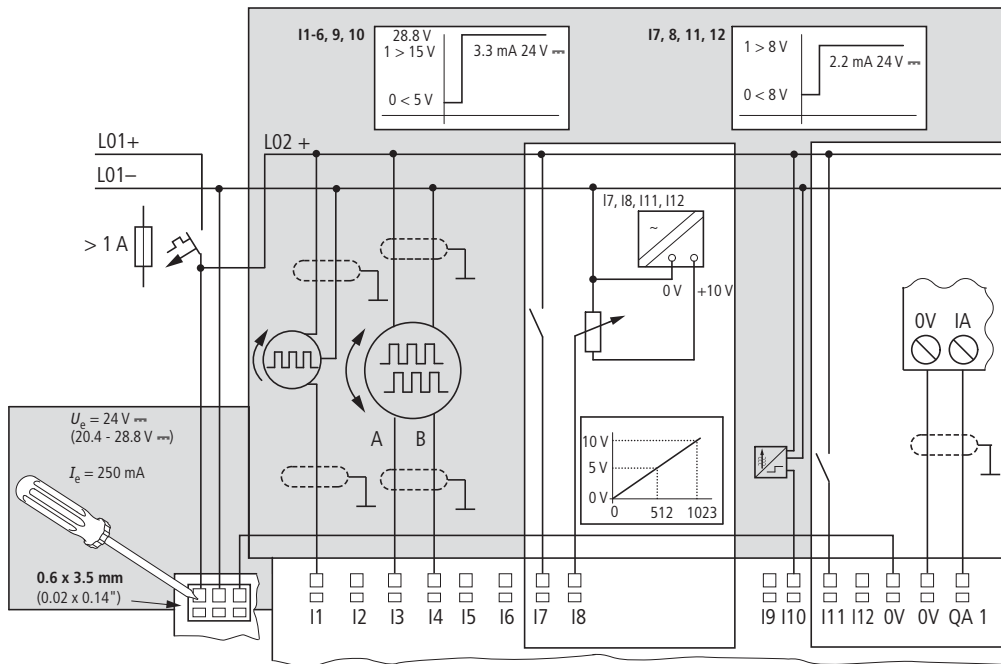

**MFD-AC-CP8... + MFD-AC-R16**

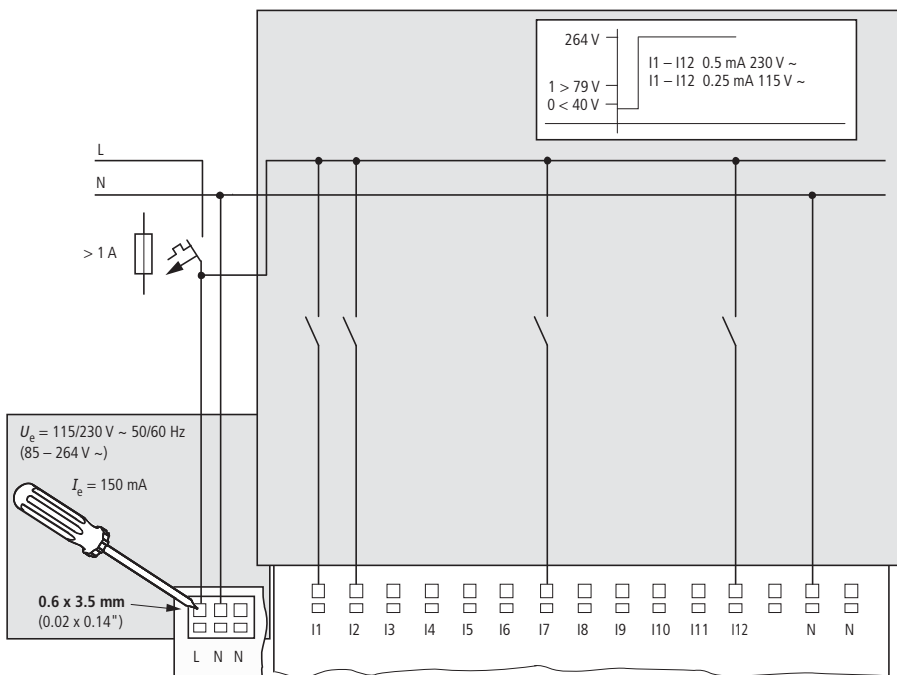

11/10 IL05013014Z

**EASY6...-DC-...E**

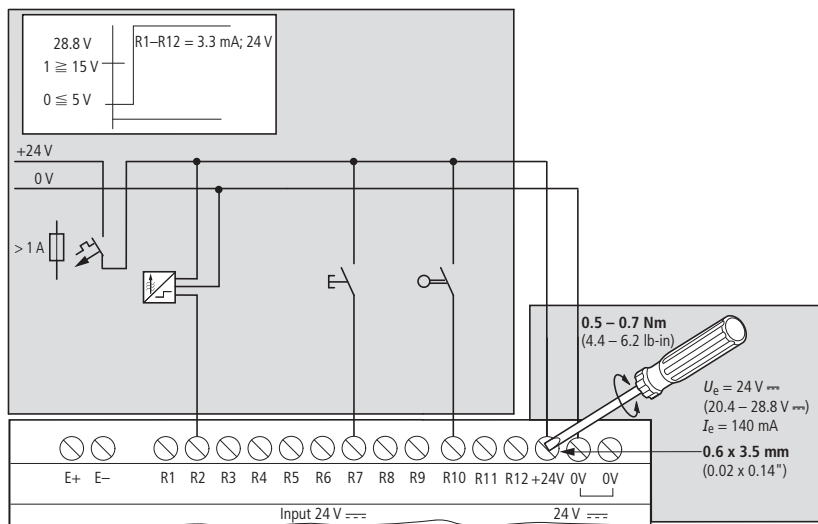

**EASY6...-AC-...E**

11/10 IL05013014Z

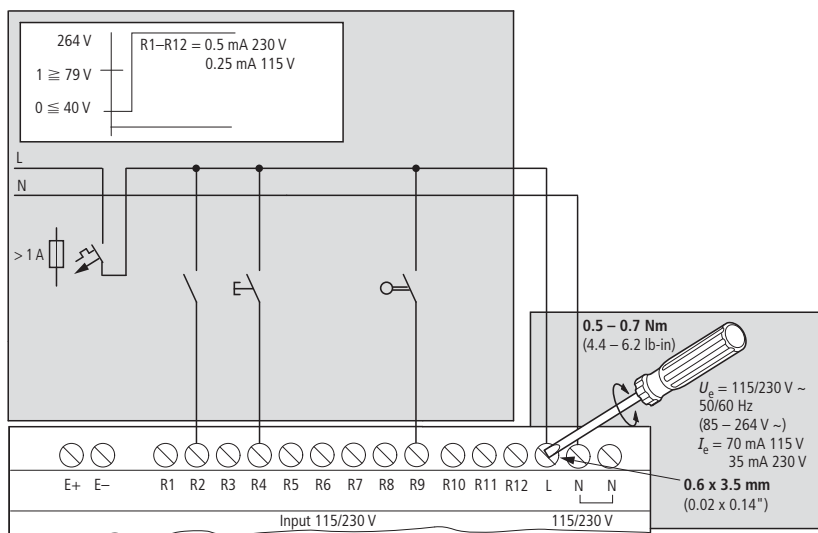

**EASY410-DC-...**

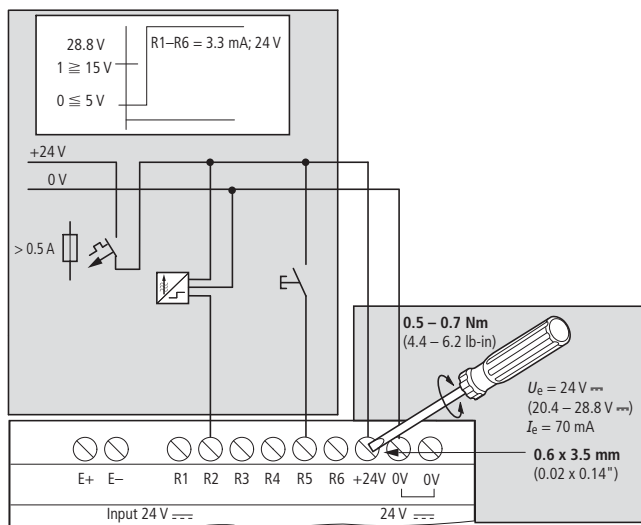

MFD-R..., EASY6...-RE, EASY410-DC-RE

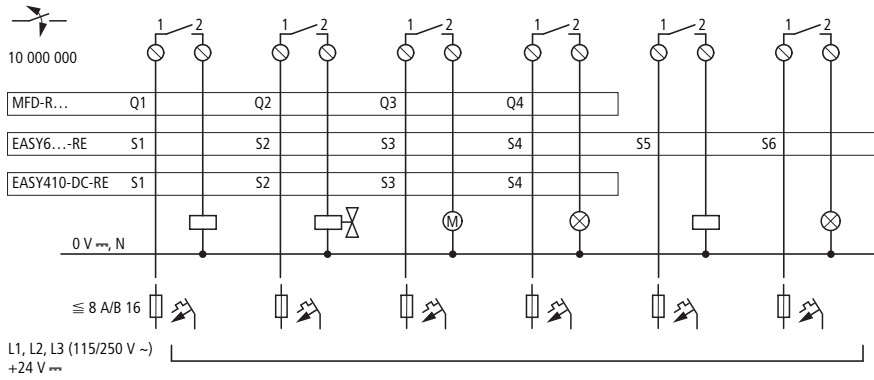

L1, L2, L3 (115/250 V ~)  
+24 V ~

R	L
24 V ~ 8 A	3 A
115 V ~ 8 A	3 A
230 V ~ 8 A	3 A
1000 W	25 000
10 × 58 W	

EASY202-RE

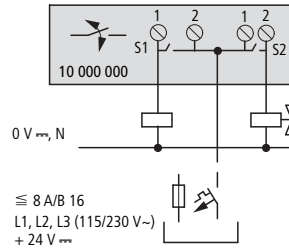

$\le 8 A/B 16$   
L1, L2, L3 (115/230 V ~)  
+24 V ~

Transistor outputs – Transistor-Ausgänge – Sorties à transistors – Salidas de transistor – Uscite a transistor

MFD-T..., EASY6...-DC-TE, EASY410-DC-TE

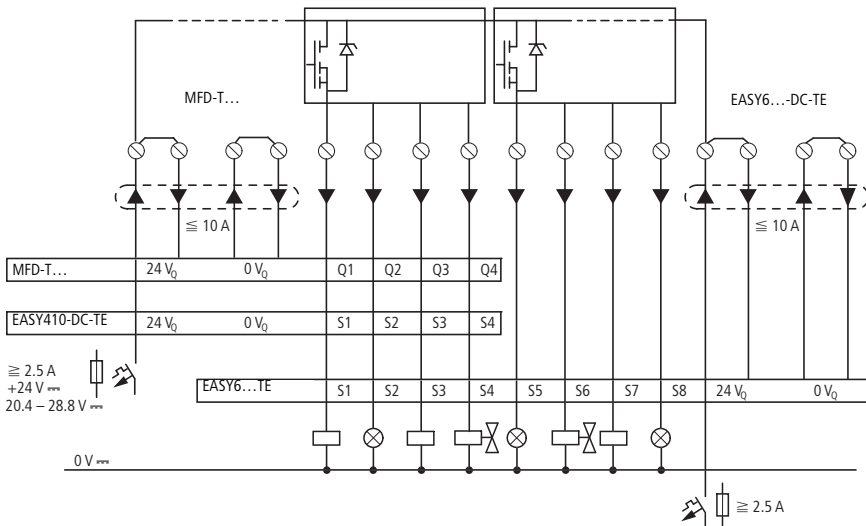

$\ge 2.5 A$   
+24 V ~  
20.4 – 28.8 V ~

$\ge 2.5 A$

MFD-T..., EASY...-DC-...

R	L
24 V ~	0.5 A
	0.5 A
5 W/24 V	

+24 V ~  
(20.4 – 28.8 V ~)

- (en) Protective circuit
- (de) Schutzbeschtaltung
- (fr) Circuit de protection
- (es) Circuito de protección
- (it) Circuito di protezione

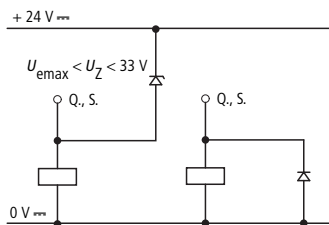

## Interface – Schnittstelle – Interfaccia



**en Warning!**

The interface must be kept closed. Electrostatic discharges may destroy the device if the interface is open

**de Warnung!**

Die Schnittstelle ist geschlossen zu halten. Elektrostatische Entladungen können bei geöffneter Schnittstelle das Gerät zerstören.

**fr Avertissement !**

Lorsqu'aucun connecteur n'est enfoncé dans l'interface, cette dernière doit impérativement être obturée à l'aide du capot prévu à cet effet (fourni avec l'appareil). Dans le cas contraire, des décharges électrostatiques risquent d'endommager gravement l'appareil et de le rendre inutilisable.

**es ¡Advertencia!**

La interface debe permanecer cerrada. De lo contrario, descargas electroestáticas podrían dañar el aparato

**it Avvertimento!**

L'interfaccia deve restare chiusa. Scariche elettrostatiche con interfaccia aperta possono distruggere l'apparecchio.

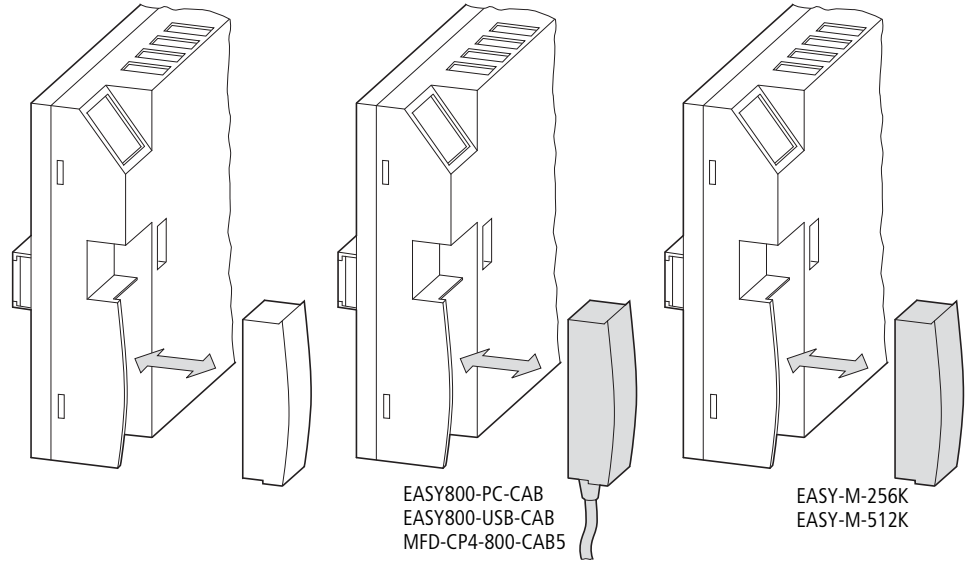

EASY800-PC-CAB  
EASY800-USB-CAB  
MFD-CP4-800-CAB5

EASY-M-256K  
EASY-M-512K

## Connections – Anschlüsse – Raccordements – Conexiones – Collegamenti

### MFD-800-CAB5

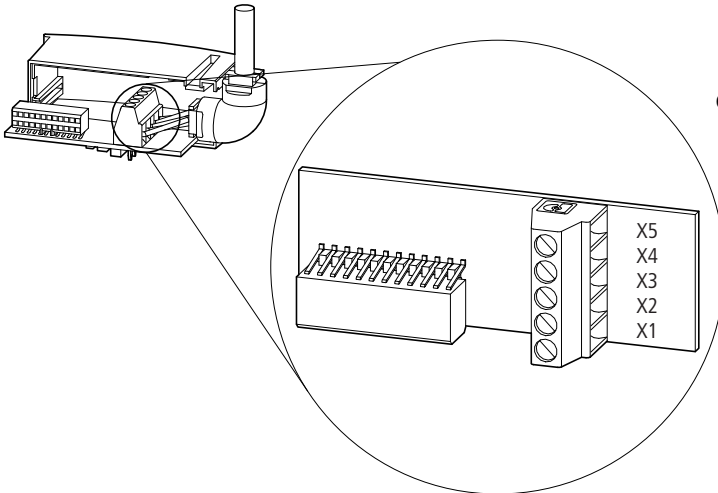

### Colour codes – Farbcodes – Codes couleur – Códigos cromáticos – Codici a colori

<b>X5</b>	green – grün – vert – verde – verde
<b>X4</b>	white – weiß – blanc – blanco – bianco
<b>X3</b>	yellow – gelb – jaune – amarillo – giallo
<b>X2</b>	brown – braun – marron – marrón – marrone
<b>X1</b>	grey – grau – gris – gris – grigio

11/10 IL05013014Z

Protective cover – Schutzhaube – Capot de protection – Tapa protectora – Calotta di protezione

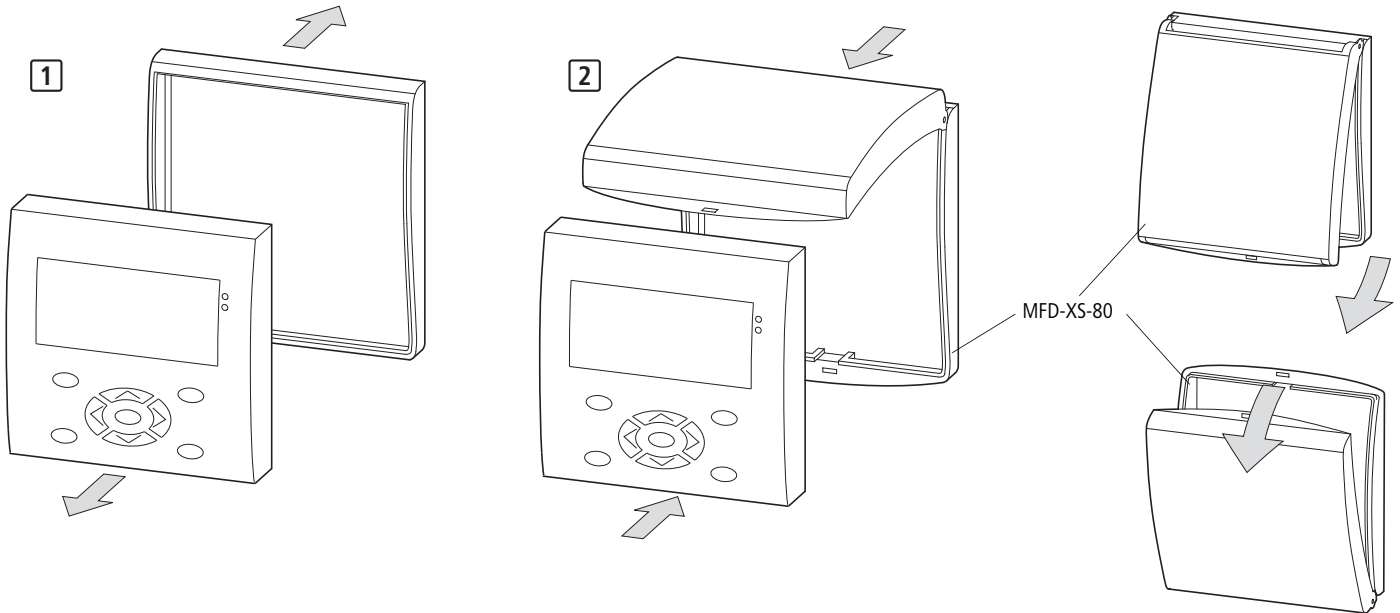

Protective diaphragm – Schutzmembrane – Membrane de protection – Membrana protectora – Membrana di protezione

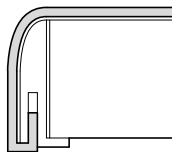
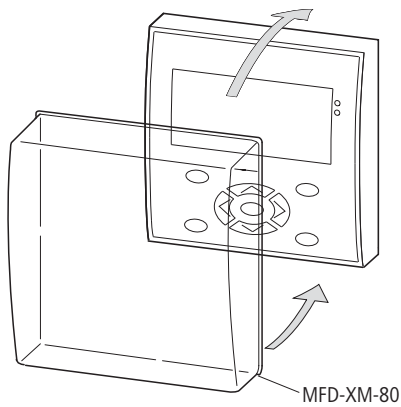

NEMA Type 4X



**(en) Caution!**

Ensure that the protective diaphragm fits snugly in the groove of the display/operating unit. Otherwise a proper seal cannot be guaranteed and particles may enter underneath the diaphragm. This may cause malfunctions in the keypad. In food industry applications, there is the risk of bacteria building up underneath the diaphragm.

**(de) Vorsicht!**

Stellen Sie sicher, dass die Schutzmembrane fest in der Nut des Anzeige-/Betriebs-Gerätes sitzt, da sonst eine ausreichende Abdichtung nicht gewährleistet ist und somit Partikel unterhalb der Membrane eindringen können. Dies kann zu Fehlfunktionen in der Tastatur führen. Bei Anwendungen in der Nahrungsmittelindustrie besteht das Risiko der Bildung von Bakterien unterhalb der Membrane.

**(fr) Attention !**

Assurez-vous que la membrane de protection est correctement insérée dans la gorge de l'unité d'affichage et de commande opérateur. Dans le cas contraire, l'étanchéité est insuffisante et des particules sont alors susceptibles de s'introduire sous la membrane, ce qui peut entraîner des dysfonctionnements au niveau du clavier. Pour les applications dans l'industrie agroalimentaire, il existe un risque de développement de bactéries sous la membrane.

**(es) ¡Atención!**

Asegúrese de que la membrana protectora se inserta bien en la muesca del aparato de visualización/funcionamiento, pues de lo contrario no podrá garantizarse una estanqueidad total y es posible que se introduzcan partículas por debajo de la membrana. Esto puede provocar funciones erróneas en el teclado. En aplicaciones en la industria alimenticia existe el riesgo de que se formen bacterias debajo de la membrana.

**(it) Attenzione!**

Assicurarsi che la membrana di protezione sia collocata saldamente nella scanalatura del display/unità operativa. In caso contrario non è garantita una tenuta sufficiente e potrebbe verificarsi l'infiltrazione di particelle sotto la membrana, con conseguente compromissione del funzionamento della tastiera. In caso d'impiego nell'industria alimentare esiste il rischio di formazione di batteri sotto la membrana.

11/10 IL05013014Z

Front mounting – Frontmontage – Montage face avant – Montaje frontal – Montaggio frontale

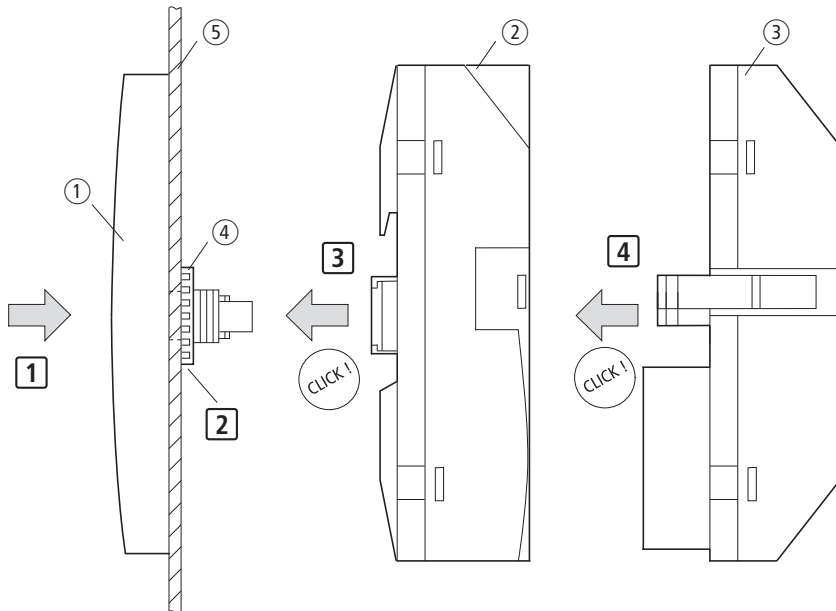

**⚠** **(en) Warning! Risk of destruction !**  
Only permitted if the device is de-energized !

**(de) Warnung ! Zerstörungsgefahr!**  
Nur im spannungsfreien Zustand erlaubt!

**(fr) Avertissement ! Risque de destruction !**  
Rischio di distruzione! Autorisé hors tension seulement !

**(es) ¡Advertencia! ¡Peligro de destrucción!**  
¡Se permite sólo en estado libre de tensión!

**(it) Avvertimento! Rischio di distruzione!**  
Consentito solo in assenza di tensione!

- ① MFD-80...
- ② MFD-...-CP8, MFD-...-CP10
- ③ MFD-...-R..., MFD-...-T...
- ④ M = 1.2 - 2 Nm  
(10.6 - 17.7 lb-in)

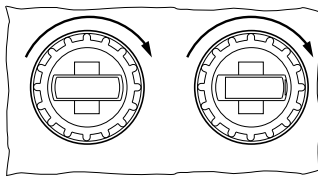
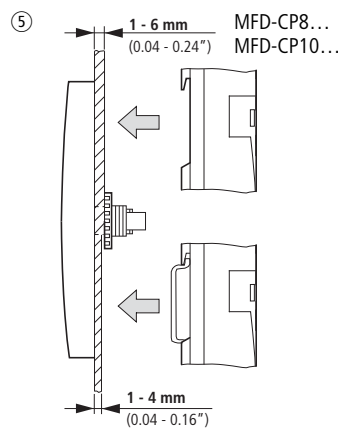

11/10 IL05013014Z

Dismantling the device – Demontage des Gerätes – Démontage d'appareil – Desmontaje del aparato – Smontaggio dell'apparecchio

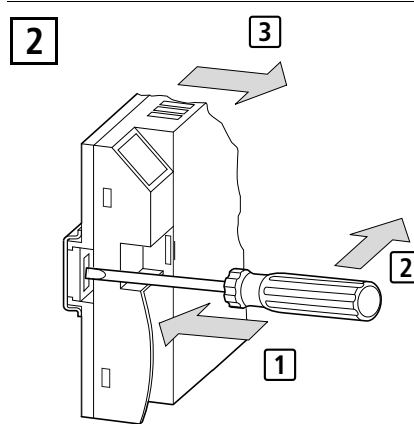
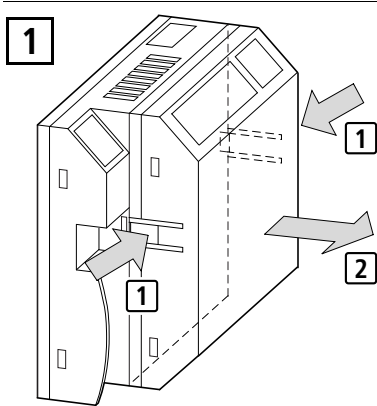

**⚠** **(en) Warning! Risk of destruction !**  
Only permitted if the device is de-energized !

**(de) Warnung ! Zerstörungsgefahr!**  
Nur im spannungsfreien Zustand erlaubt!

**(fr) Avertissement ! Risque de destruction !**  
Rischio di distruzione! Autorisé hors tension seulement !

**(es) ¡Advertencia! ¡Peligro de destrucción!**  
¡Se permite sólo en estado libre de tensión!

**(it) Avvertimento! Rischio di distruzione!**  
Consentito solo in assenza di tensione!

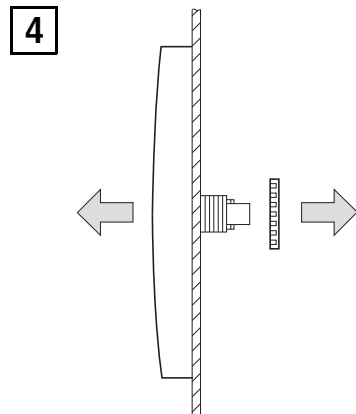
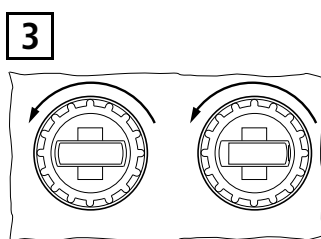

1

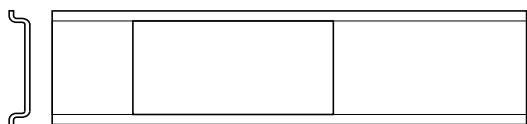

2

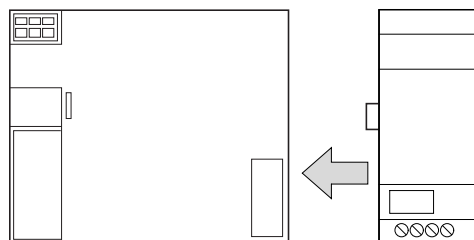

3

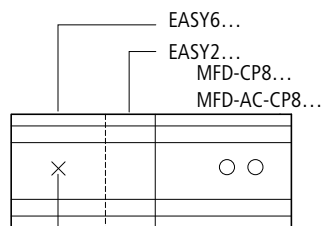
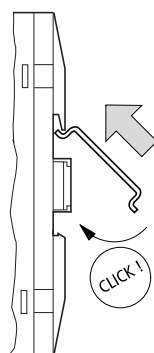
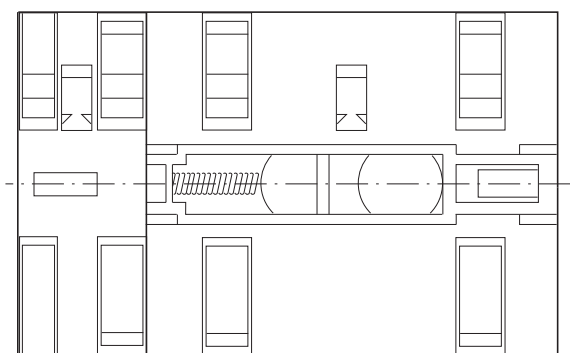

3rd support – 3. Stütze – 3e support – 3.º apoyo – 3o supporto

4

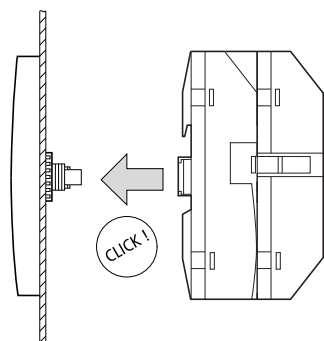

**en Caution!**

Without additional 3rd support, only expansion units with a width of 2 modules are possible.



**de Vorsicht!**

Ohne zusätzliche 3. Stütze sind nur Erweiterungsgeräte mit 2 TE Baubreite erlaubt.



**fr Attention !**

Sans 3ème support supplémentaire, seules les extensions avec une largeur de 2 PE sont admises.



**es ¡Atención!**

Sin un 3.º soporte adicional sólo se pueden utilizar aparatos de ampliación con una anchura total de 2 UM.



**it Attenzione!**

Senza 3° supporto aggiuntivo, sono ammesse soltanto unità di espansione larghe 2 moduli.

Dismantling – Demontage – Démontage – Desmontaje – Smontaggio [4] → [3] → [2]

**3rd support – 3. Stütze – 3e support – 3.º apoyo – 3o supporto**

Top-hat rail with cut-out – Hutschiene mit Ausschnitt – Profilé-support avec découpe – Guía simétrica con sección – Guida DIN a scatto con apertura

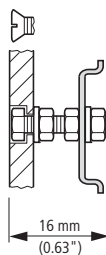
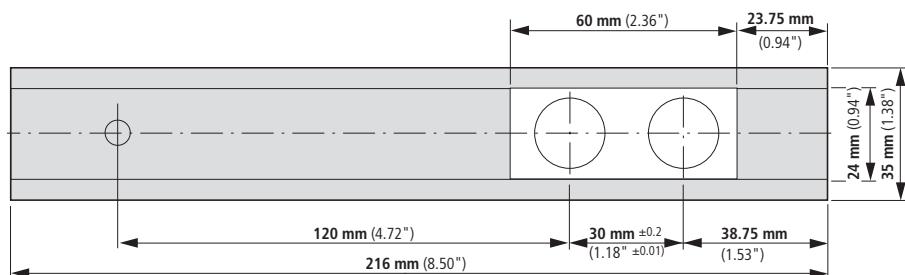

IP65

## Fitting – Montage – Montaje – Montaggio

- en on 35 mm top-hat rail
- de auf 35-mm-Hutschiene
- fr sur profilé-support 35 mm
- es sobre guía simétrica de 35 mm
- it su guida DIN 35 mm

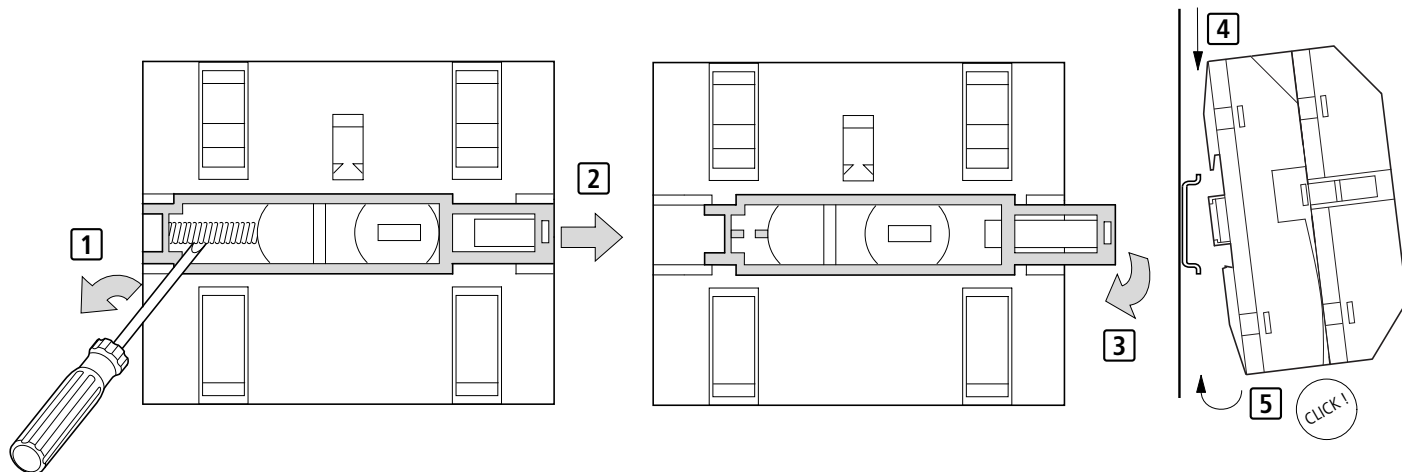

## Mounting position – Einbaulage – Position de montage – Posición de montaje – Posizione di montaggio

- en with top-hat rail (horizontal and vertical)
- de mit Hutschiene (waagrecht und senkrecht)
- fr sur profilé chapeau (horizontale et verticale)
- es sobre carril (horizontal y vertical)
- it su guida DIN (orizzontale e verticale)

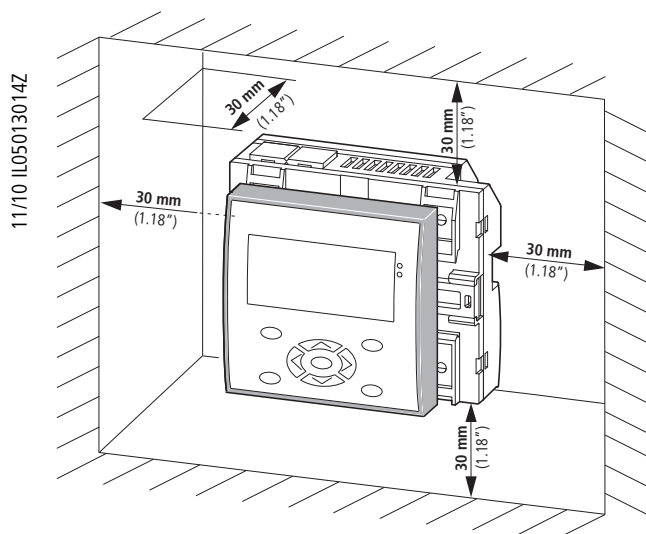

11/10 IL05013014Z

- en **Template for holes, scale 1 : 1**
- de **Bohrschablone M 1 : 1**
- fr **Gabarit de perçage, échelle 1 : 1**
- es **Plantilla para taladros, escala 1 : 1**
- it **Dima di foratura, scala 1 : 1**

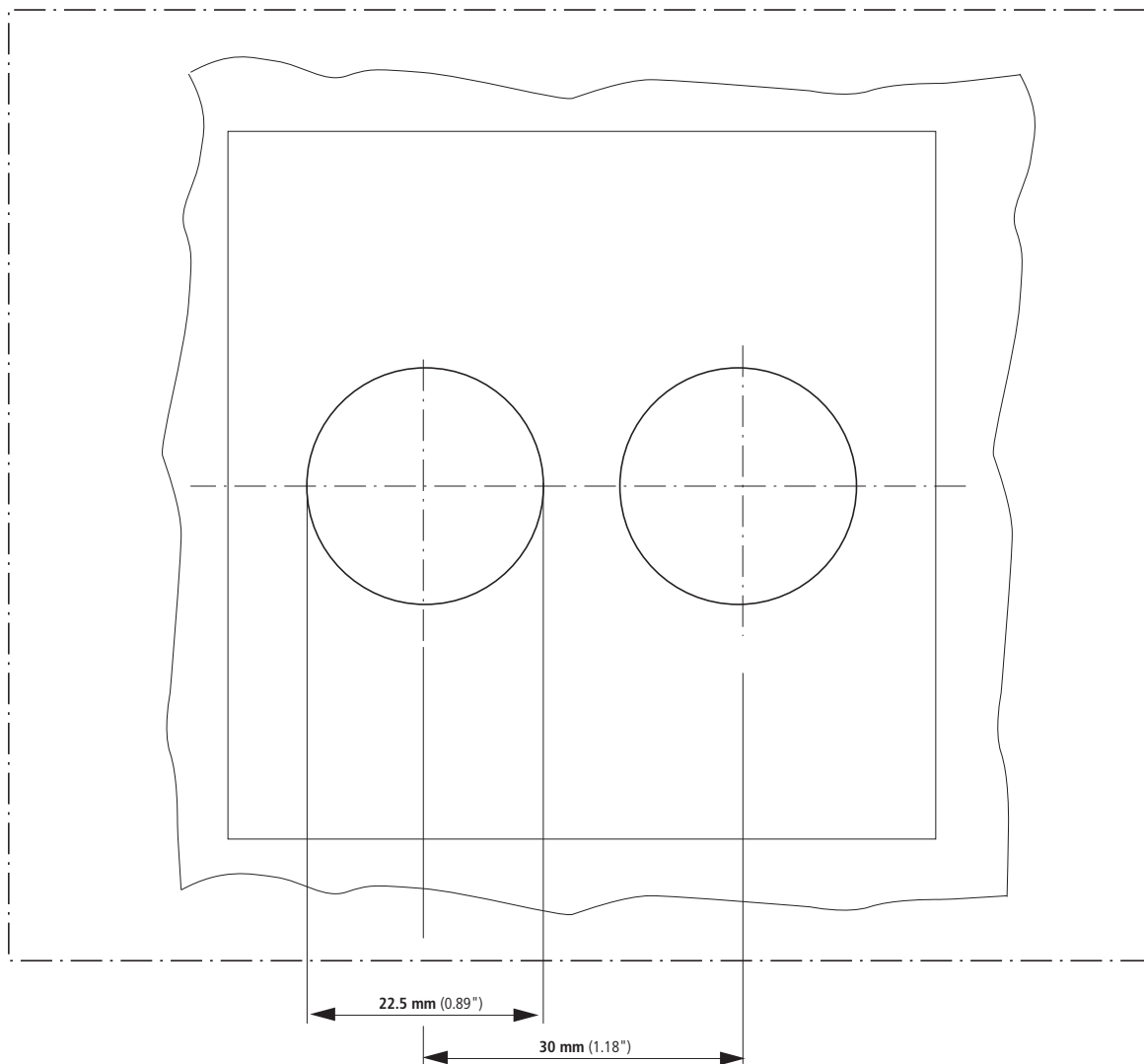

11/10 IL05013014Z

**HAZARDOUS LOCATION – CSA (Canadian Standards Association) Certification**

This equipment is suitable for use in CLASS I, DIVISION 2, GROUPS A, B, C AND D

**WARNING:** "EXPLOSION HAZARD – DO NOT DISCONNECT WHILE CIRCUIT IS LIVE UNLESS AREA IS KNOWN TO BE NON-HAZARDOUS"

**EMPLACEMENTS DANGEREUX – Certification CSA (Canadian Standards Association)**

Cet équipement est acceptable pour utilisation dans les EMBLEMES DANGEREUX DE CLASSE I, DIVISION 2, GROUPES A, B, C ET D

**AVERTISSEMENT :** « RISQUE D'EXPLOSION. NE PAS DÉBRANCHER TANT QUE LE CIRCUIT EST SOUS TENSION, A MOINS QU'IL NE S'AGISSE D'UN EMBLEMES NON DANGEREUX »